

# ***FHD Wireless Video Surveillance System***

## **User's Manual**

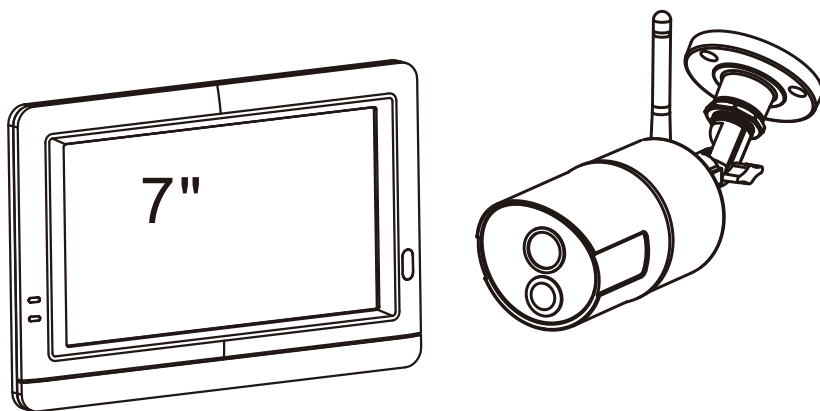

Available on the  
**App Store**

**Google play**



Please read carefully before using this equipment.

# FCC Information

This device complies with part 15 of the FCC Rules. Operation is subject to the following two conditions: (1) This device may not cause harmful interference, and (2) this device must accept any interference received, including interference that may cause undesired operation.

# Industry Canada (IC) Compliance Statement

This device complies with Industry Canada licence-exempt RSS standard(s). Operation is subject to the following two conditions: (1) this device may not cause interference, and (2) this device must accept any interference, including interference that may cause undesired operation of the device.

# Industrie Canada (IC) Déclaration de conformité

Le présent appareil est conforme aux CNR d'Industrie Canada applicables aux appareils radio exempts de licence. L'exploitation est autorisée aux deux conditions suivantes : (1) l'appareil ne doit pas produire de brouillage, et (2) l'utilisateur de l'appareil doit accepter tout brouillage radioélectrique subi, même si le brouillage est susceptible d'en compromettre le fonctionnement.

## CAUTION:

- To comply with FCC RF exposure compliance requirements, a separation distance of at least 20 cm must be maintained between the antenna of this device and all persons.
- This Transmitter must not be co-located or operating in conjunction with any other antenna or transmitter.
- Changes or modifications to this unit not expressly approved by the party responsible for compliance could void the user authority to operate the equipment.

**NOTE:** This equipment has been tested and found to comply with the limits for a Class B digital device, pursuant to Part 15 of the FCC Rules and ICES-003 of Industry Canada. These limits are designed to provide reasonable protection against harmful interference in a residential installation. This equipment generates, uses and can radiate radio frequency energy and, if not installed and used in accordance with the instructions, may cause harmful interference to radio communications. However, there is no guarantee that interference will not occur in a particular installation. If this equipment does cause harmful interference to radio or television reception, which can be determined by turning the equipment off and on, the user is encouraged to try to correct the interference by one or more of the following measures:

- Reorient or relocate the receiving antenna.
- Increase the separation between the equipment and receiver.
- Connect the equipment to an outlet on a circuit different from that to which the receiver is connected.
- Consult the dealer or an experienced radio/TV technician for help.

# Installation & Notices

1. Avoid mounting the camera close to windows, air conditioner, heater, refrigerator, oven, sunshine and places where the temperature changes fast or the air stream flows frequently.

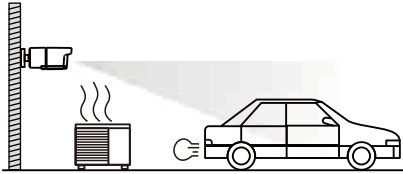

💡 *Note: Avoid positioning close to or facing to heat sources.*

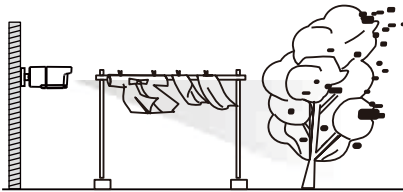

💡 *Note: Avoid facing to swinging objects.*



💡 *Note: Avoid sunlight direct reaching to sensor or facing to glass windows.*

2. Motion activity

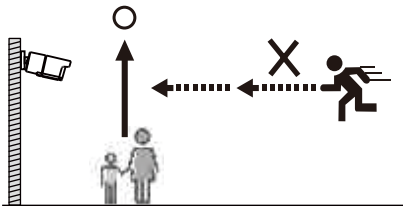

💡 *Note: Motion activity by horizontally moving.*

## Package Contents

- One camera
- One monitor
- Two power adapters (9V/800mA for Camera, 5V/3A for Monitor)
- Three screws and three anchors
- One antenna
- One allen key
- One ethernet cable
- User's manual

## Product Layout

### Camera

1. Antenna
2. Pairing button
3. Allen screw
4. Mounting bracket
5. Screw for mounting
6. Infrared LEDs (Twenty LEDs provide infrared for night vision)
7. Power LED
8. PIR(Passive Infrared Sensor)
9. Lens
10. Light sensor

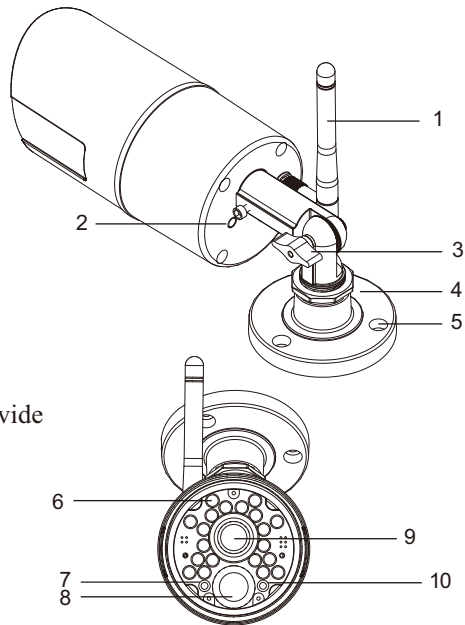

### Monitor

1. Antenna
2. Menu button
3. Alert LED
4. Power LED
5. Power ON/OFF switch
6. MicroSD card slot
7. USB connector (USB 2.0) for HDD
8. HDMI connector
9. Power adapter plug
10. Speaker
11. Stand
12. Ethernet port
13. Channel switching @ HDMI output

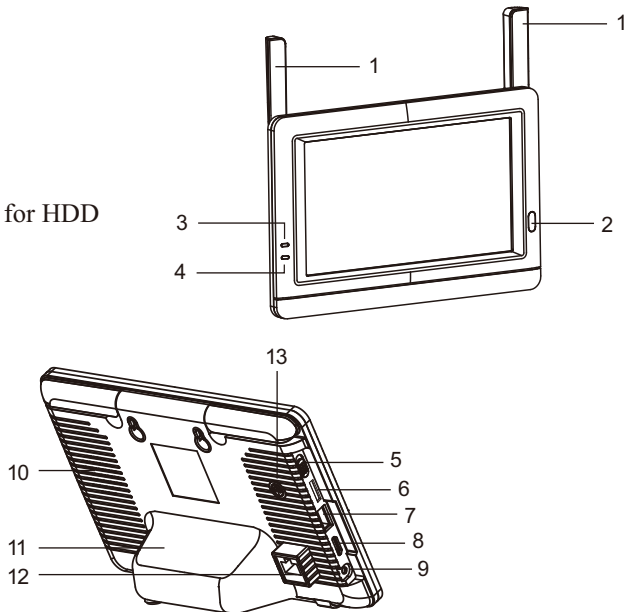

# 1 Setting up the Camera

- 1.1 Twist the antenna clockwise onto the antenna port on the back of the camera.

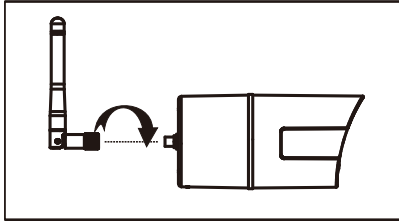

- 1.2 Use the included mounting screws to mount the camera to the mounting surface:

- \* Mark the positions of the screw holes on the mounting surface.
- \* Drill holes and insert the anchor (included) as needed.
- \* Firmly attach the camera to the mounting surface using the included screws.

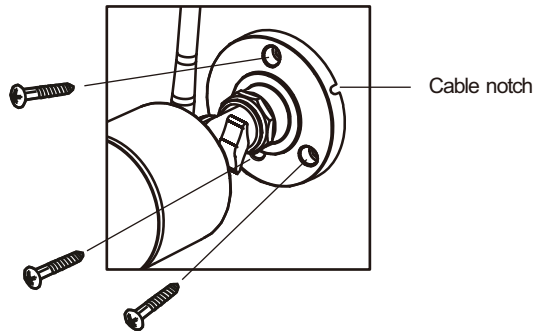
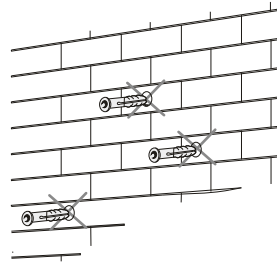

Loosen the allen screw (1), (2) and the adjustment ring (3) by turning them counter clockwise.

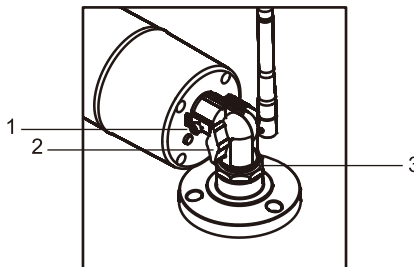

- 1.4 Adjust the angle of the cameras until the desired view is set. Tighten the allen screw, and the adjustment ring to secure each camera's position.
- 1.5 Connect the plug of the power adapter with the power in the socket of the cable from the camera. Make sure power plug is pushed all the way in. Plug the power adapter into a wall outlet.

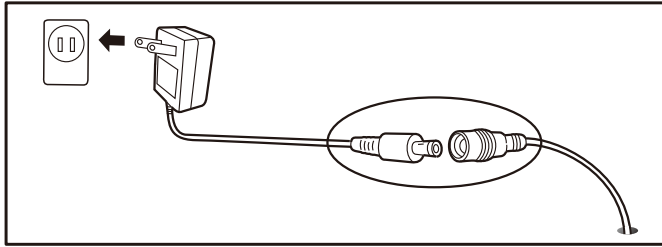

## 2 Setting up the Monitor

- 2.1 Peel off the plastic cover that is protecting the LCD display.
- 2.2 The system is designed for MicroSD card recording. Please insert a MicroSD card into the Micro SD card slot in the monitor if you want to record video. The system supports MicroSD cards with a maximum capacity of 256GB.

 **Note:** The package doesn't include a MicroSD card.

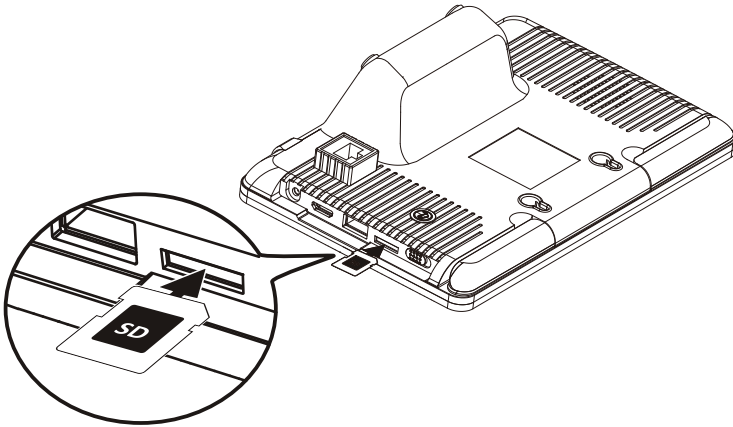

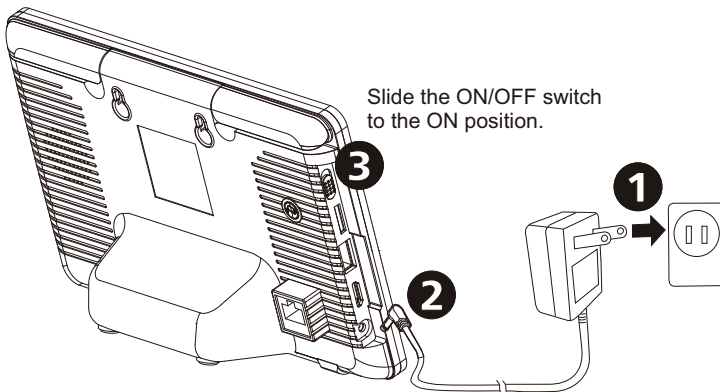

- 2.3 Plug one end of the provided power adapter into a wall outlet and the other end into the monitor. Slide the power switch to the ON position.



 **Note:** The battery needs to be fully charged before you turn on the monitor for the first time.

## 2.4 LED indicator

LED	Status
 Alert	Glows blue when the camera has detected motion. Flashes blue if the system is unlinked.
 Power	Glows green when powered on. Glows orange when charging. Flashes red if the battery is running low.

 **Note:** When a certain alert event has been viewed on the device, then tap the screen or press the Menu button, the LED will turn off.







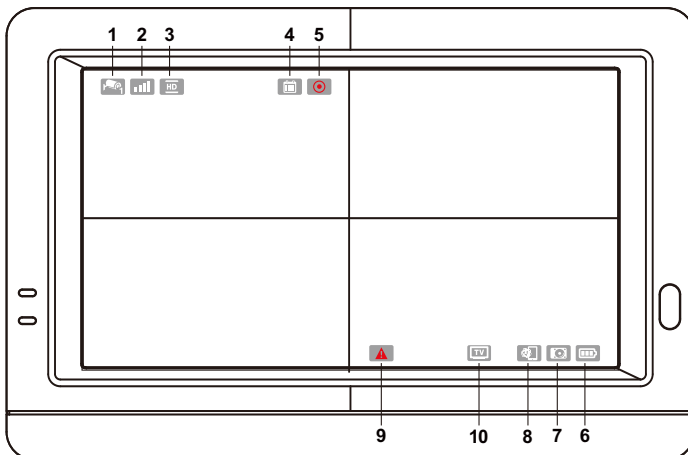

## 2.5 Changing How the Live Screen Displays

The live screen displays in three view (Quad view, Dual view or Single view) that depends on how many cameras have been selected in the Menu (Menu --> Camera --> Selection). If there is only one camera has been selected, the live view screen will only display a Single view. If two cameras have been selected, the live view screen can be switched between Single view and Dual view. If three or four cameras have been selected, the live view screen can be switched between Single view and Quad view. If you are in Dual view or Quad view, tap on the camera image area you want to expand to Single view. Tap on that image to return to Dual view or Quad view.

## 2.6 On-Screen Icons





1. **Camera Number:** Displays the camera number.
  -  (White Icon): Displays the camera image and also provides audio.
  -  (Gray Icon): Only displays the camera image.
2. **Signal Strength:** Shows the strength of the signal being received.
3. **Resolution:** Displays the current resolution of the camera you are viewing.
  -  FHD (1080P) resolution.
  -  HD (720p) resolution.
4. **Recording modes:** Displays the current event that has been scheduled to record. There are 3 modes for recording (Motion detection / Schedule / Manual).
  -  Motion recording
  -  Schedule recording
5. **Record Status:** If the recording symbol is red, this indicates that the device is currently recording. You can also tap this icon to start recording manually. Tap again to stop recording.
6. **Battery Capacity:** Displays battery capacity.
7. **Storage:** This icon indicates that an HDD / MicroSD card has been inserted into the system.
  -  A HDD or MicroSD is currently inserted.
  -  **Full** The HDD or MicroSD is currently full. It will display the icon when the Non-overwrite function has been selected in the Menu (Menu --> Record --> Non-overwrite) and the HDD or MicroSD is full.  
The HDD icon indicator turns red when the HDD is getting too full.
  -  A HDD or MicroSD has not been inserted.
- 💡 **Note:** Safely remove the HDD, you can tap the icon to quickly and safely eject HDD to prevent data loss.
8. **Remote viewing:** The icon indicates that someone is connected to the device using the app. The icon will disappear when the app is no longer connected to the device.
9. **Upgrade FW:** The icon indicates that a new FW needs to be updated. The icon will disappear when the FW is the latest.

10. **TV icon:** The icon indicates that the HDMI cable has been connected to the monitor, tap the icon and the video/audio signal will output to the display device.

## 2.7 HDMI output

1. Connect an HDMI cable between monitor and display device.
2. Tap the "TV" icon. The video/audio signal will output to the display device when the monitor is in the live screen display.
3. Press the "Channel switching" button on the back of the monitor to switch the cameras and change to a single/quad view.
4. When the video/audio signal outputs to the display device, press the menu button "⏏" on the monitor and the video/audio signal will return to the monitor.

💡 **Note:** The system compatible with HDMI 1.4

## 2.8 Recording to hard disk drive

1. Connect a USB cable between the monitor and hard disk drive.
2. External USB hard disk for recording, it is compatible with USB 2.0 and maximum capacity is 2TB.

💡 **Note:** Safely remove hard disk: When you use the external HDD, you should *safely remove* them before unplugging them to prevent data loss and such problems. Please click on the "HDD icon" on live view to eject an HDD.

## 3 Menu Options

Press the menu button ⏏ on the monitor to display the main menu on the screen; Press again to return live view when it is in the menu.

The main menu contains 6 sub-menus.

💡 **Note:** In menu, if you don't tap the screen or press the Menu button, after 1 minute, the screen will return to live view automatically.

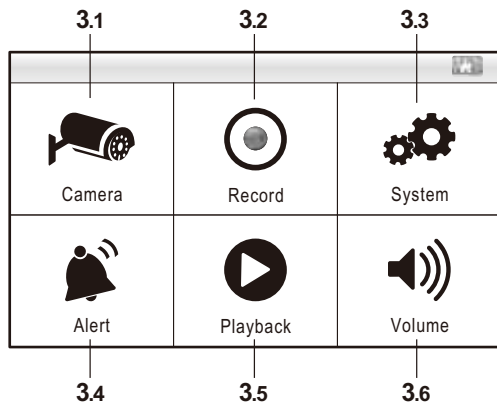

# Menu Layout

## Main Menu

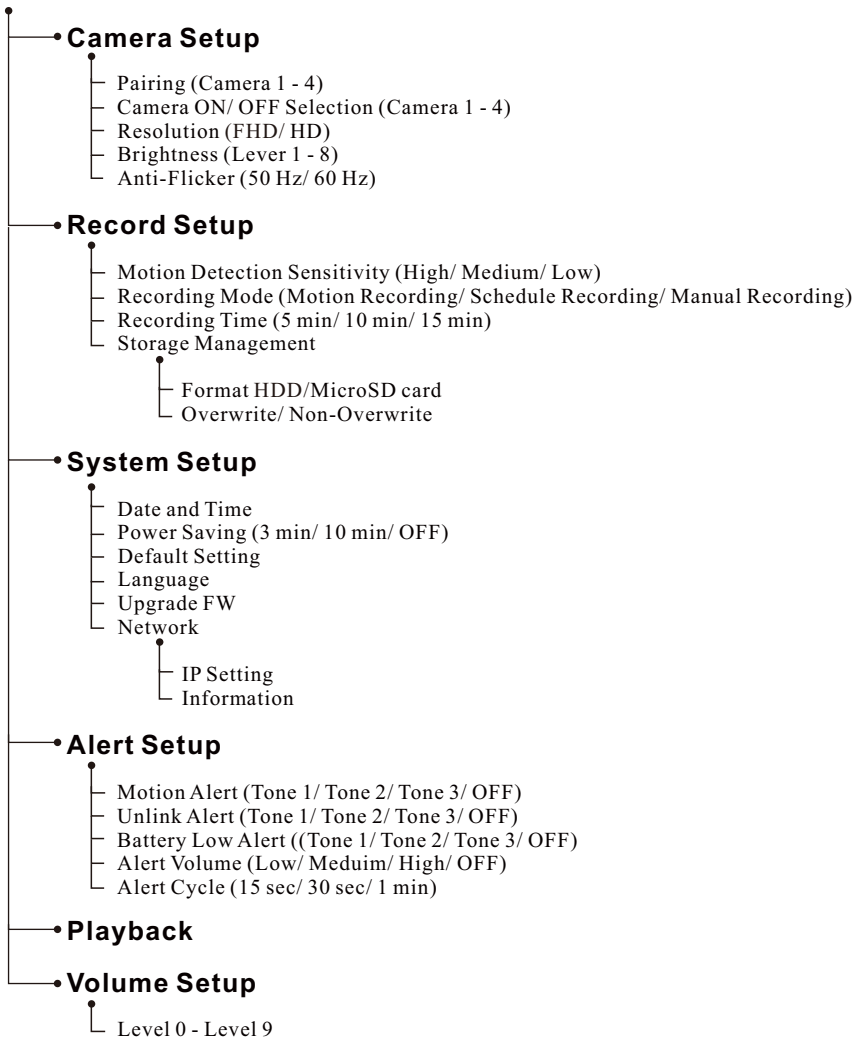

### 3.1 Camera Setup

3.1.1 *The camera menu contains 5 sub-menus.*

#### **Pairing:**

If you have purchased addition cameras, use the pairing function to add the cameras. You will also need to use the pairing button located at the back of the camera.

1. Tap the camera number you want to pair at the screen you will see a small pairing animation underneath the camera selection.
2. Use a paperclip or pen to press the pair button at the back of the camera. The red Power LED of the camera will start to flash.
3. After a short moment, the LED will stop flashing and you will see an image from the camera on screen. The camera is now paired.

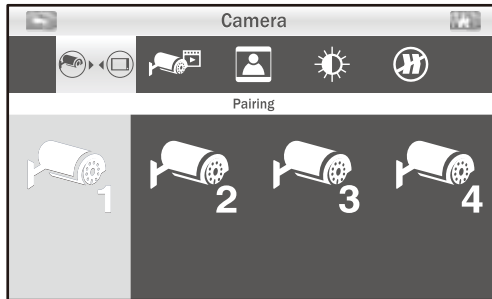

#### 3.1.2 **Camera Selection:**

The camera selection function is useful if you have multiple cameras configured. If only one camera that has been selected, the live view screen will only display the Single view. If two cameras have been selected, the live view screen can be switched between Single view and Dual view. If three or four cameras have been selected, the live view screen can be switched between single view and Quad view.

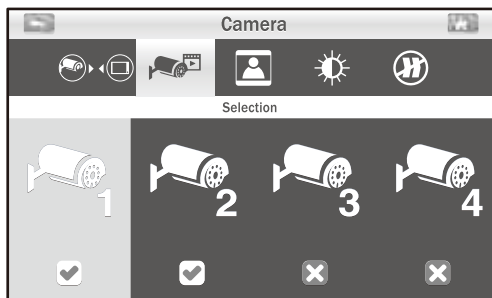

### 3.1.3 Resolution:

In this submenu you can setup each camera's resolution individually. You have the option of viewing and recording your camera(s) in HD (720p) or FHD (1080P).

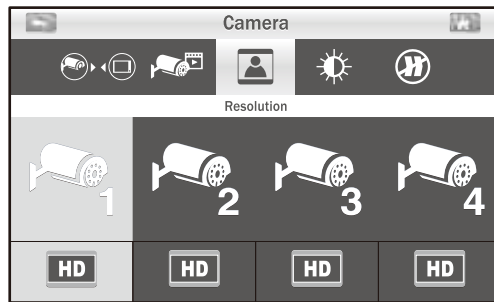

### 3.1.4 Brightness:

In this submenu you can change the brightness for each camera that is configured. Repeatedly tap the camera to select the desired brightness level from 1 to 8.

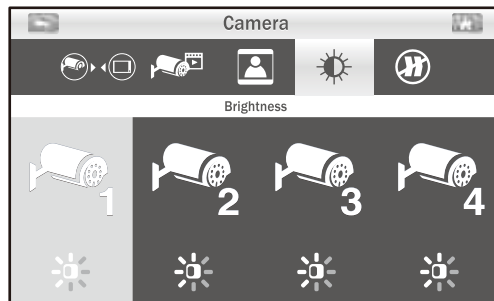

### 3.1.5 Anti-flicker:

If you find that the camera(s) have a flicker effect cause by indoor lighting, this indicates that the anti-flicker function is not set correctly. Tap the correct setting for your particular country.

- 💡 **Note** : 50Hz : Europe, Australia, Africa, Asia, China and Japan(East).  
60Hz : America, Taiwan, Korea and Japan(West).

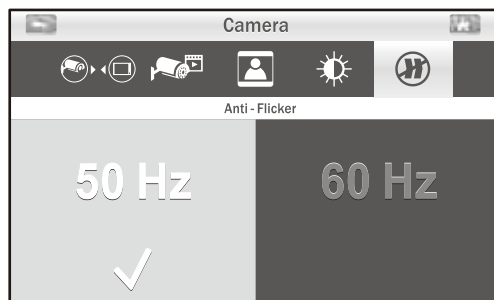





## 3.2 Record Setup

The record menu contains 4 sub-menus.

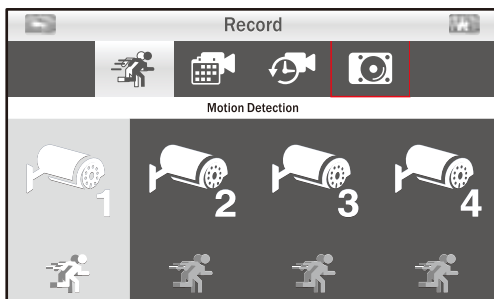
### 3.2.1 Motion Detection Sensitivity:



In this submenu you can repeatedly tap the camera to change the motion detection sensitivity for each camera. You have the choice of low, medium and high.



3.2.2 **Record mode:** Tap the screen to select the time sections and set up the recording type. The system offers 3 types of recording: Manual  , Time Schedule  and Motion detection  .

By default, motion detection is enabled for each camera.

- (1) Tap a camera that you would like to configure.
- (2) Tap on the icon to change the event type.
- (3) Tap the icon  to go to the second page displaying 12:00pm to 23:00pm.

**Note :**   Motion recording: System only records when motion is detected by the camera and will stop recording after 30 seconds from when the last motion was detected.



### 3.2.3 Recording Time:

In this submenu you can select the recording time for each recording file.

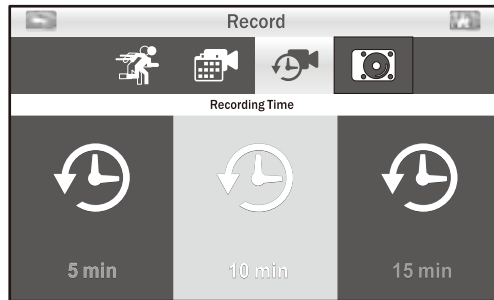



### 3.2.4 Storage Management:

*This menu contains 2 sub-menus.*

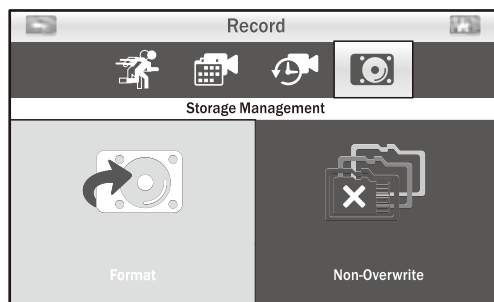
1. **Format backup device:** Tap Format icon to format the HDD or MicroSD Card. Formatting the device will remove all files that you have on there.
2. **Overwrite:** The function allows you to select if you would like to overwrite file when the card is full or to stop recording. Tap the option that is relevant to your needs.



- 💡 **Note:** The system would automatically detects whether or not an SD card or HDD is connected. When both SD card and HDD are connected, the system will auto switch to HDD.
- 💡 **Note:** The system supports 2 types of storage devices, one is SD card  , the other is the HDD  . The icon will show up on the monitor.

### 3.3 System Setup

The system menu contains 6 sub-menus.

#### 3.3.1 Date and Time:

This function allows you to configure the date and time. Tap the "+" and "-" icons to adjust it.

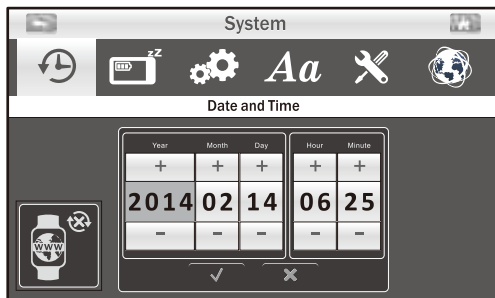

**NTP Clock:** Tap the icon  to automatically synchronize system clock with a Network Time Protocol (NTP) time server.

#### 3.3.2 Power Saving:

To conserve battery power, the power saving feature will turn off the display after a set time of in-activity. Tap "OFF" to disable power saving. When the display has turned off, tap the screen to turn it on again.

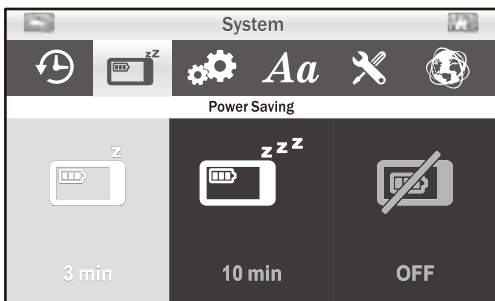

#### 3.3.3 Default setting:

The function will reset the system to factory default settings.

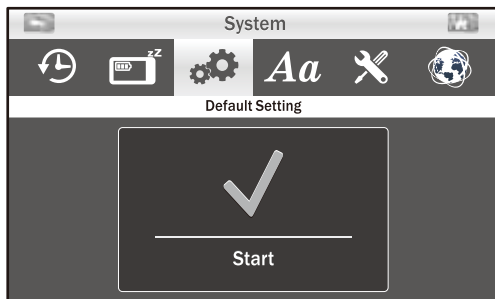

 **Note:** Pairing settings will not be affected by the default setting function. The camera will remain connected with the monitor.



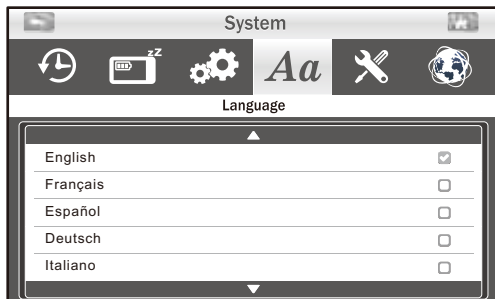

### 3.3.4 Language:

This function allows you to change to the language that you prefer.



### 3.3.5 Upgrade FW:

If the monitor has a connection to Internet, it will auto detect if there any new version firmware that can be updated. If there is a new version firmware, the icon  will change to . Tap the icon  and follow the steps on-screen to upgrade your system.

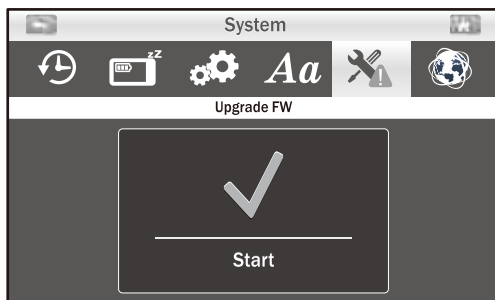

 **Warning:** The firmware upgrade process must not be interrupted or the system may be damaged. If the system firmware is the latest, it will display the message, as below.



 **Warning:** To make your system work properly, we strongly recommend that you update the firmware to the latest version.

### 3.3.6

## Network:

This menu contains 2 sub-menus that allow you to configure your network settings.

1. **IP Setting:** The default setting is DHCP and the IP number that has been provided to the monitor by your router. There is not much to do here unless you want to use a “Static IP”. We don't recommend using static IP unless you have some experience with networking. The default setting works fine.

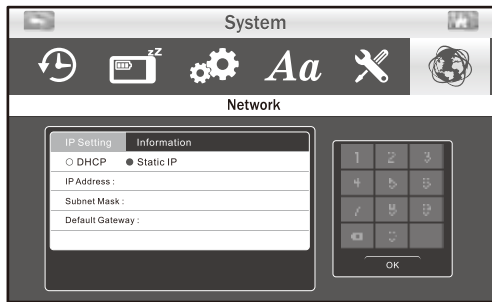

2. **Information:** The display information includes the network settings UID number. Also the default password is 12345, and you can change the password using your smartphone or tablet.

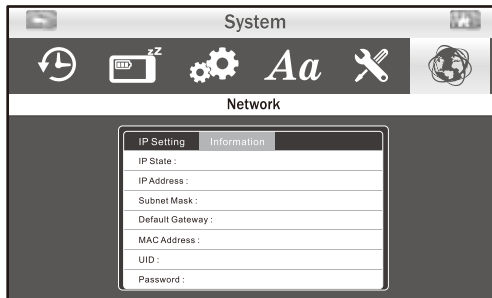

### 3.4 Alert Setup

The alert menu contains 5 sub-menus.

#### 3.4.1 Motion Alert:

This selection allows you to choose the alert tones or disable the alerts for motion detection.

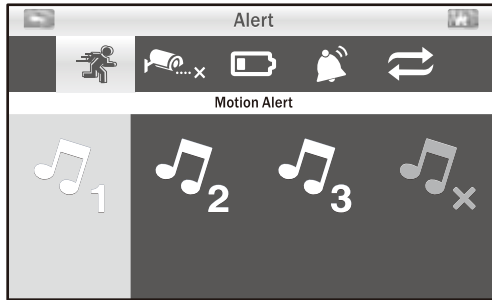

#### 3.4.2 Unlink Alert:

This selection allows you to choose the alert tones or disable the alerts when the cameras disconnected.

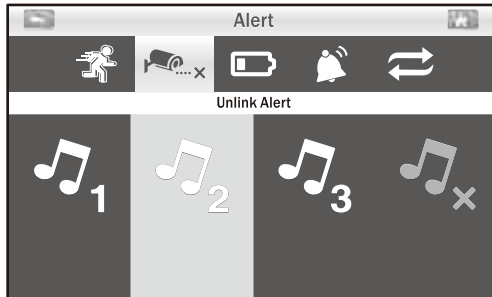

#### 3.4.3 Battery Alert:

This selection allows you to choose the alert tones or disable the alerts when low on battery.

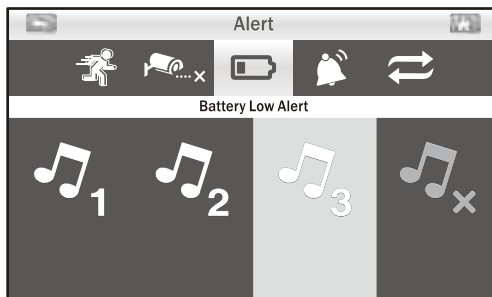

### 3.4.4 Alert Volume:

This function allows you to increase / decrease the volume or turn off the alert sound.

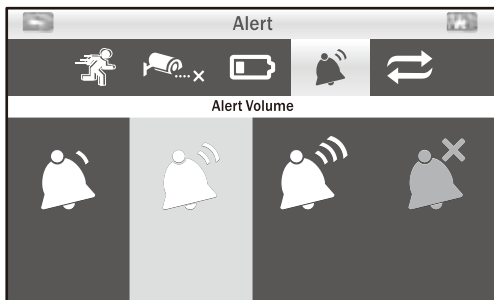

### 3.4.5 Cycle:

This function allows you to adjust the time duration between each alert.

💡 **Note :** When the alert tone has been heard, tap the screen or press the Menu button; the alert tone will be stopped.

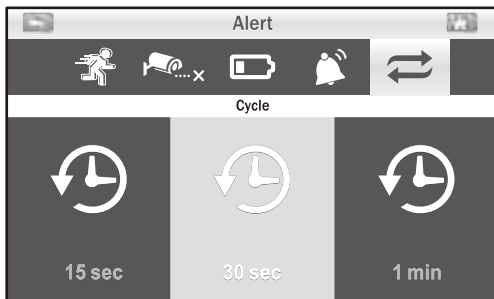

## 3.5 Playback

*Recording files are managed based on date and time.*

1. Tap a date folder (YYYY/MM/DD) that you prefer to view.

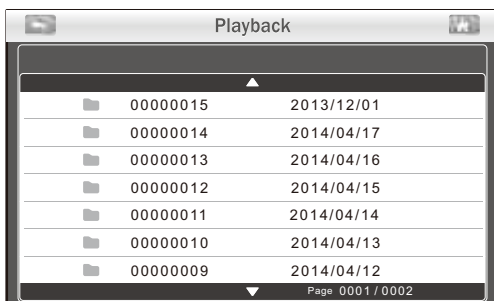

2. Tap on the file to play the event.

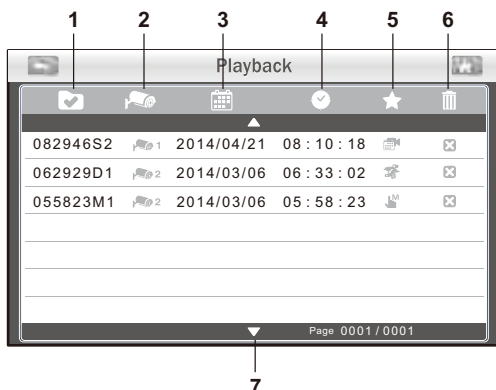

1. File name
2. Camera number
3. Event date
4. Event time
5. Event type
6. Tap the [X] button to delete an event
7. Next page

3. When playing the recording file, tap the play button ► for pause/play, tap the right button ►► for fast forward, and tap the left button ◀◀ for fast backward.

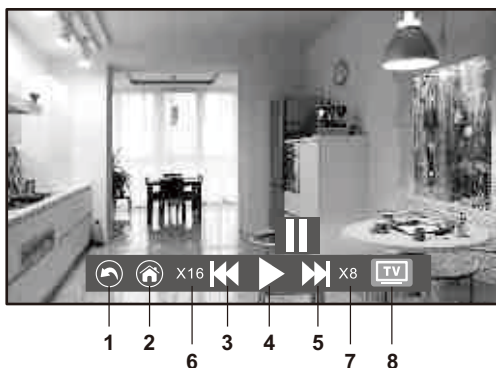

1. Return to file list
2. Return to live view
3. Fast backward
4. Pause / Play
5. Fast forward
6. Backward speed
7. Forward speed
8. Playback on display device.

### 3.6 Volume Setup 🔊

Tap the volume up button 🔊 and volume down button 🔊 to adjust volume level.

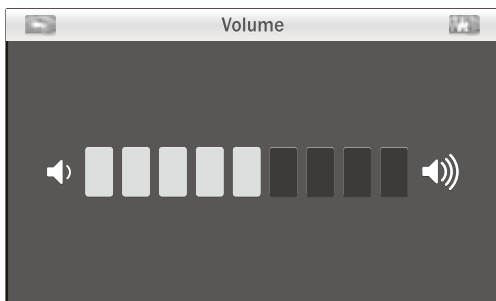

## 4 Remote Access Function

From the system, you can monitor your home on your smartphone or table at any time, from anywhere in the world.

### 4.1 Before Setting Up

1. Make sure your home router is turned on and it can connect to Internet.
2. An Ethernet connection is required for remote access function. Connect the Ethernet cable to the LAN connection on the monitor, and then connect the other end to a spare port on your router.

 **Note:** If your router is a Wi-Fi router, please make sure the distance between the monitor and the Wi-Fi router is a distance of over one meter to provide better performance.

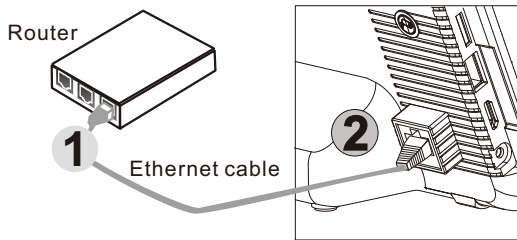

3. Download iHomeCam app: To download the iHomeCam app, go to the “Apple App Store” or “Android Market (Google Play)”, and search for “iHomeCam” from your smartphone or tablet. Follow the on-screen instructions for installation.

### 4.2 Setting Up And Using iHomeCam for iPhone/iPad

#### 4.2.1 Add Device

1. After download and installing the app on your smartphone or tablet, locate the app and tap the icon to launch the app.



2. Tap the  icon then tap “QR Code” to scan the QR code located on the rear of the monitor. You can also tap “Add” to manually input the UID instead of scanning the QR code.

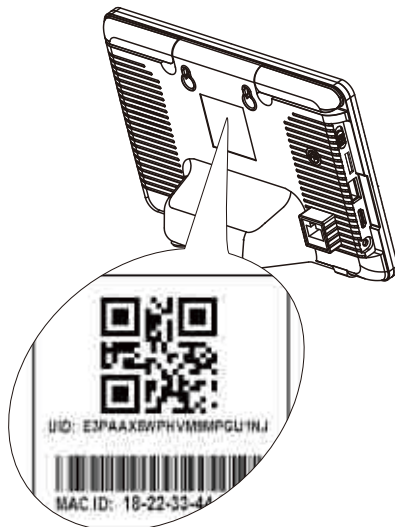

The UID and QR code label is on the rear of the monitor.

3. Hold your mobile device close to the QR code to scan. When the code is successfully scanned, the UID field will be populated automatically.
4. Give the camera a new name or leave it as displayed. Enter the default password “12345”, and then tap “Save” to finish the device setup.

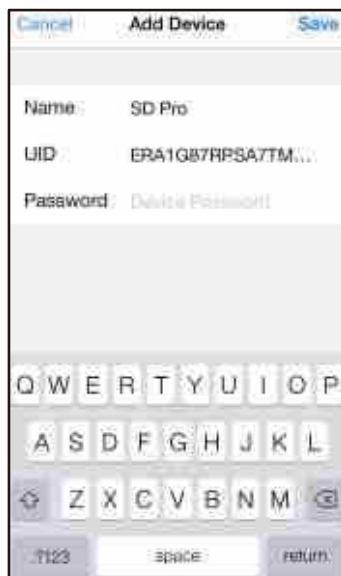

#### 4.2.2 Device List Screen

Tap the  icon and you will see the device list screen.

1. **Device photo:** Tap the device photo to view a live video.

2. **Device name:** When you launch the app, all the devices you have added will be shown on the screen.

3. **Device status:**  
a. **Online:** If the device status shows “Online”, you can tap the device photo to see the live video of the device.  
b. **Connection:** If the device status shows “Connection”, you need to wait until the status changes to online, and then tap the device photo to see the live video of the device.

c. **Offline:** If the device status shows “Offline”, you need to tap the icon  beside the device name, and then tap “Connection Status” to re-confirm the Internet connection.

4. **Device UID**
5. **Edit device** function
6. **Device list** function
7. **Searching events** function
8. **Add new device** function
9. **App information**
10. **Edit device:** Tap the icon to select which device you want to delete.

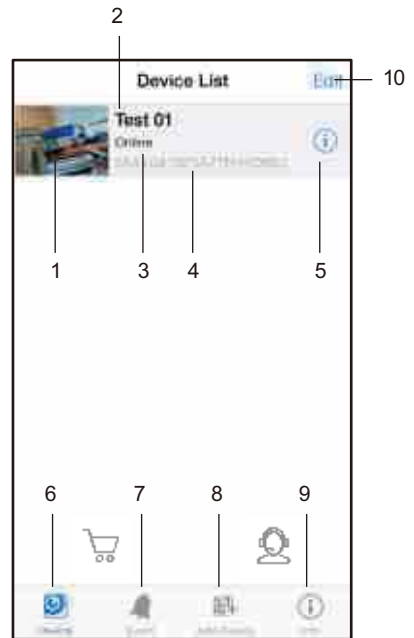



### 4.2.3 Live Video Screen

Tap the device photo on the “Device List” screen and you can see a live video from the camera. Camera 1 will be displayed by default. If you have multiple cameras configured, tap “Channel” and select the camera that you want to view.

- 1. Camera information:** Includes camera status, video resolution, online number and connection quality.
- 2. Photo:** Tap the icon to see all of the photos you have taken.
- 3. Snapshot:** Tap the icon to save a snapshot of the camera on your smartphone or tablet.
- 4. Audio ON/OFF:** Tap the icon to hear the audio from the camera. Tap again to mute.
- 5. Back:** Tap to return to the “Device List” screen.
- 6. Device name** and camera number.
- 7. Camera selection:** If you have multiple cameras configured, tap this to select a different camera to view.

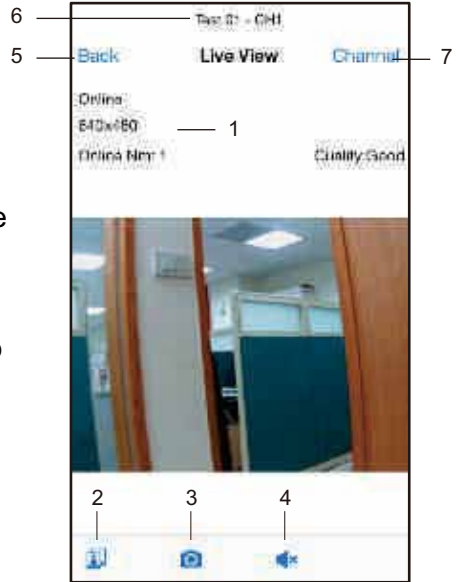

#### 4.2.4 Device Setting (Edit Device)

Tap the ⓘ icon beside the device name on the “Device List” screen to switch the screen to “Edit Device” .

1. **Back:** Tap this to return to “Device List” screen.
2. **Name:** Tap this if you want to change the device name.
3. **Password:** If you have changed the device password with another smartphone or tablet, you need to tap the row to correct the password.
4. **Advance Settings:** Tap this to enter advance settings.
5. **Reconnect:** Tap this to re-confirm the Internet connection if the camera status shows as being offline.

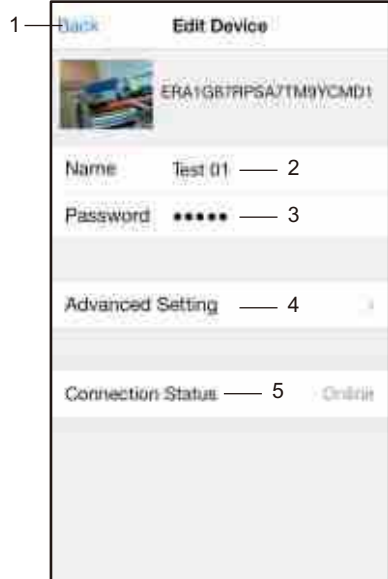

#### 4.2.5

### Advance Settings

Within the settings screen you can change the default password, alter the video quality and increase or decrease the interval time for alerts.

1. **Modify Password:** If you want to change the password, please tap this row to carry out the change.

💡 **Note:** If you have changed the password, you can refer to the new password on the menu (Menu -> System -> Network) at the monitor unit.

2. **Video Quality:** Tap this to change the video quality for the video. Adjusting the video quality may help if you're having problems when viewing the live video stream.

💡 **Note:** **FHD:** high video quality but low frame rate.  
**HD:** medium video quality and medium frame rate.  
**QHD:** High frame rate but low video quality.

3. **Alert Interval:** Tap this to adjust the time that the app will alert you when there is an event. You also have the option of turning off alerts.
4. **Device Info:** Tap this to see basic network information about your device.

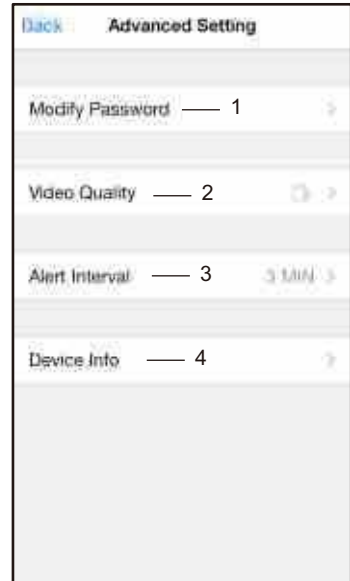

#### 4.2.6 Searching Events Function

Tap the  icon then tap > from the “Device List” screen. From the “Event List” screen, tap “Search” to select different search criteria. By tapping “Custom”, you can specify a date and time period to search for events. A list of all video events matching your search criteria will be displayed. Tap an event to play.

 **Note:** There is only video and no audio when you play an event file.

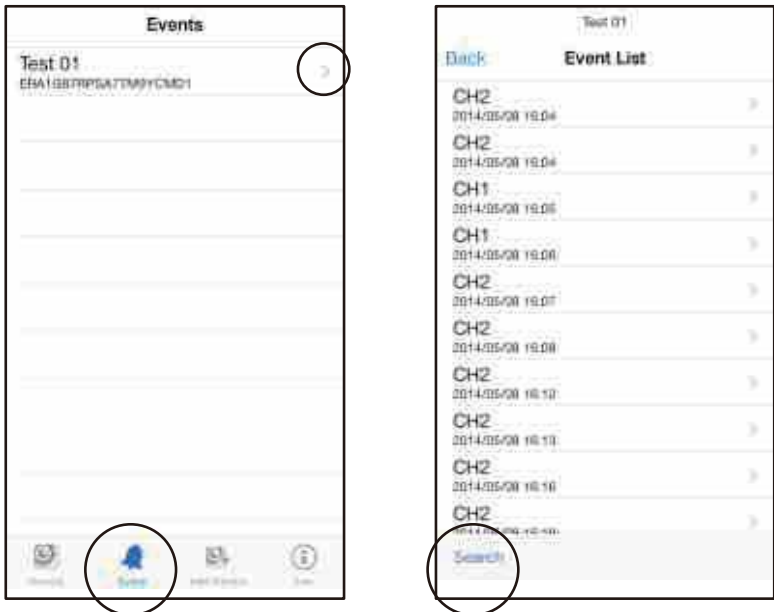

### 4.3 Setting Up And Using iHomeCam for the Android System

#### 4.3.1 Add Device

1. After downloading and installing the app on your smartphone or tablet, locate the app and tap the icon to launch the app.



2. Tap the  icon to enter “Add Device” screen. The UID and QR code are located at the rear of the monitor. You can manually input the UID or tap “Scan” to scan the QR code. Please hold your smartphone or tablet close to the QR code to scan.

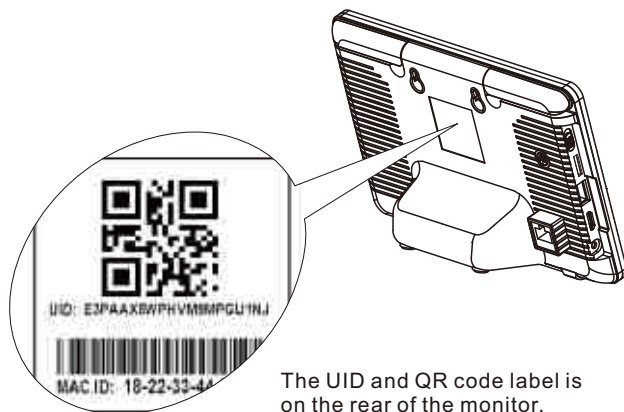
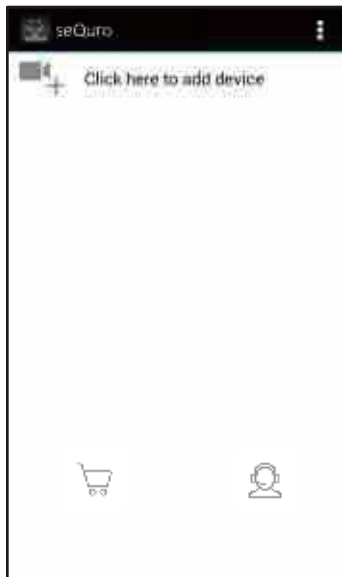

The UID and QR code label is on the rear of the monitor.

3. Give the device a new name or leave it as displayed. Enter the default password “12345”, and then tap “OK” to finish the device setup.

#### 4.3.2 Device List Screen

1. **Device photo:** Tap the device photo to view a live video.
2. **Device name:** When you launch the app, all the devices you have added will be shown on the screen.
3. **Device status:**
  - a. **Online:** If the device status shows “Online”, you can tap the device photo to see the live video of the device.
  - b. **Connection:** If the device status shows “Connection”, you need to wait until the status changes to online, and then tap the device photo to see the live video of the
  - c. **Offline:** If the device status shows “Offline”, you need to tap the ☹ icon beside the device name, and then tap “Reconnect” to re-confirm the Internet connection.
4. **Device UID**
5. **Advanced function**
6. **Add new device**
7. **Add new device / App information / Exit**

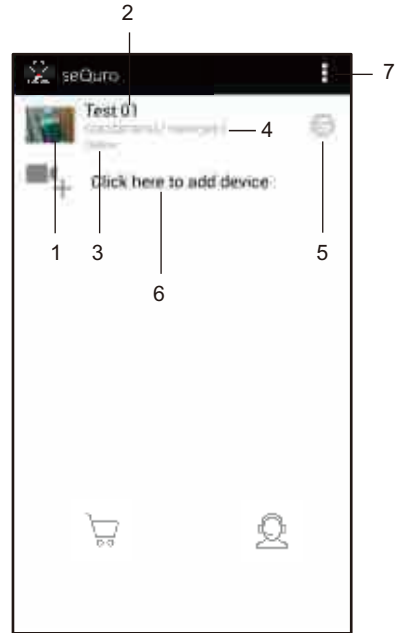

### 4.3.3 Live Video Screen

Tap the device photo on the “Device List” screen and you can see a live video from the camera. Camera 1 will be displayed by default. If you have multiple cameras configured, tap the  icon and select the camera that you want to view.

1. **Camera information:** That includes camera status, video resolution, online number and connection quality.
2. **Photo:** Tap the icon to see all of the photos you have taken.
3. **Snapshot:** Tap the icon to save a snapshot of the camera on your smartphone or tablet.
4. **Audio ON/OFF:** Tap the icon to hear the audio from the camera. Tap again to mute.
5. **Device name and camera number.**
6. **Camera selection:** If you have multiple cameras configured, tap this to select a different camera to view.



#### 4.3.4 Device Setting (Edit Device)

Tap the ☺ icon on the “Device List” screen, and then select “Edit Device” to switch the screen to “Edit Device”.

1. **Name:** Tap this if you want to change the device name.
2. **Password:** If you have changed the device password with another smartphone or tablet, you need to tap the row to correct the password.
3. **Advance Setting:** Tap this to enter advance setting.

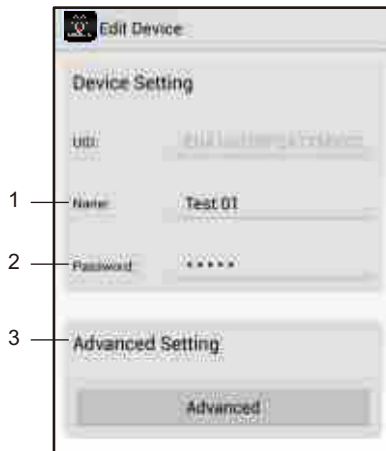

#### 4.3.5 Advance Settings

Tap “Advanced” on the “Edit Device” screen to enter “Advanced Setting”.

1. **Modify Password:** If you want to change the password, please tap this row to carry out the change.  
  
 **Note:** If you have changed the password, you can refer to the new password on the menu (Menu -> System -> Network) at the monitor unit.
2. **Video Quality:** Tap this to change the video quality for the video. Adjusting the video quality may help if you're having problems when viewing the live video stream.





- 💡 **Note:** **FHD:** high video quality but low frame rate.  
**HD:** medium video quality and medium frame rate.  
**QHD:** High frame rate but low video quality.

3. **Alert Interval:** Tap this to adjust the time that the app will alert you when there is an event. You also have the option of turning off alerts.
4. **Device Info:** Tap this to see basic network information about your device..

#### 4.3.6 Searching Events Function

Tap the ☹ icon on “Device List” screen, and then select “View Event” to switch the screen to “View Event”.

1. **Event list:** A list of all video events matching your search criteria will be displayed here. Tap an event to play.

- 💡 **Note:** There is only video and no audio when you play an event file.

2. Tap the icon to select different search criteria. By tapping “Custom”, you can specify a date and time period to search for events.



# Troubleshooting

## You don't getting any signal at all

- Make sure the camera and the monitor are turned on.
- Make sure the power plugs are pushed all the way in.

## If the signal is poor, or there is interference

- If there is a microwave oven in use in the path between camera and monitor, remove the microwave oven or turn it off.
- Make sure the camera and the monitor are within range of each other. (range of approximately 1000 feet; 300 meters in a clear line of sight)

# Care and Maintenance

- Keep all parts and accessories out of children's reach.
- Fingerprints or dirt on the lens surface can adversely affect camera performances. Avoid touching the lens surface with your fingers.
- Should the lens become dirty, use a blower to blow off dirt and dust, or a soft, dry cloth to wipe off the lens.
- Do not attempt to open the case. Non-expert handling of the device may damage the system.
- Avoid dropping or strong shocks.
- Operate this product using only with the power supply included or provided as an accessory.
- Do not overload electrical outlets or extension cords this can result in fire or electric shocks.
- The terms HDMI and HDMI high-Definition Multimedia Interface, and the HDMI Logo are trademarks or registered trademarks of HDMI Licensing LLC in the United States and other countries.

# Specifications

Camera		Monitor	
Frequency	2.4 GHz	Frequency	2.4 GHz
Antenna	Dipole antenna	Antenna	Dipole antenna
Transmission distance	300m (Line of Sight)	LCD Screen Size	7-inch
Modulation	GFSK, FHSS	Display colors	Full-color
Image Sensor	Color CMOS	Motion Alarm	Yes
Effective pixels	1920H x 1080V pixels	Dimensions(WxHxD)	198 x130 x 28 mm
Lens	f4.0mm, F 2.0	Weight	450 g
IR LED	20 pcs (10 meters)	Power	DC 5V, 3A or 3.7V Li-ion battery
Dimensions(WxHxD)	129 x 60 x 67 mm (W/O stand)	Operating temperature	0°C ~ 40°C (32°F ~ 104°F)
Weight	460 g		
Power	DC 9V, 800mA		
Operating temperature	-10°C ~ 50°C (14°F ~ 122°F)		

*Specifications subject to change without notice*



This item is in compliance with the essential requirements and other relevant provisions of Directive 1999/5/E.C.



